

LEGO Mindstorms EV3 Dancing Robot Build Instructions



Right Leg



1

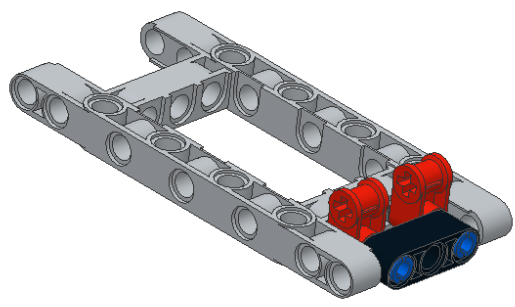
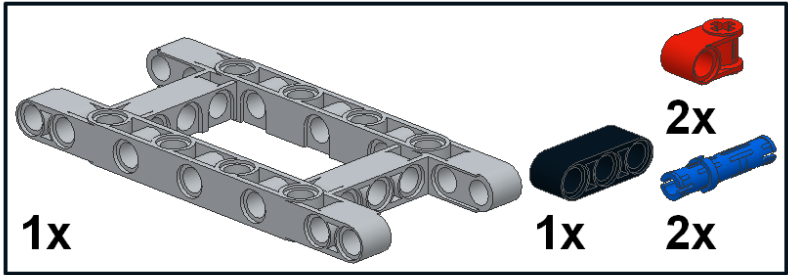

2

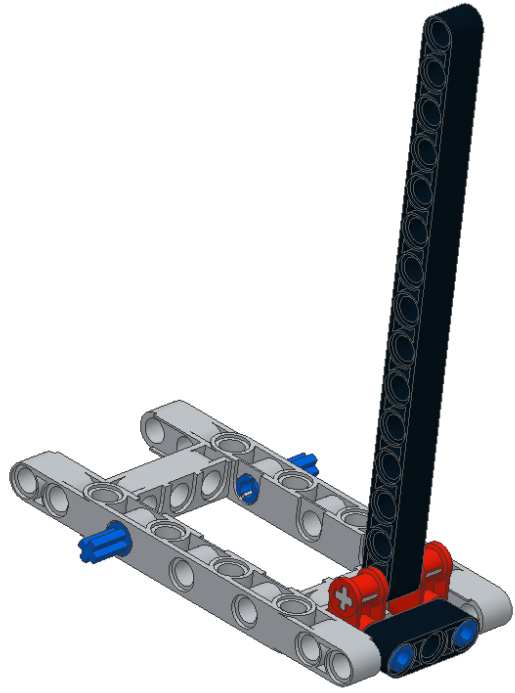
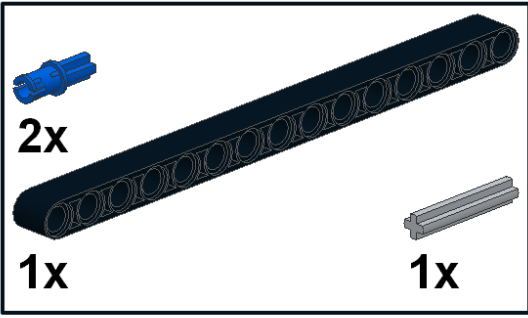

3

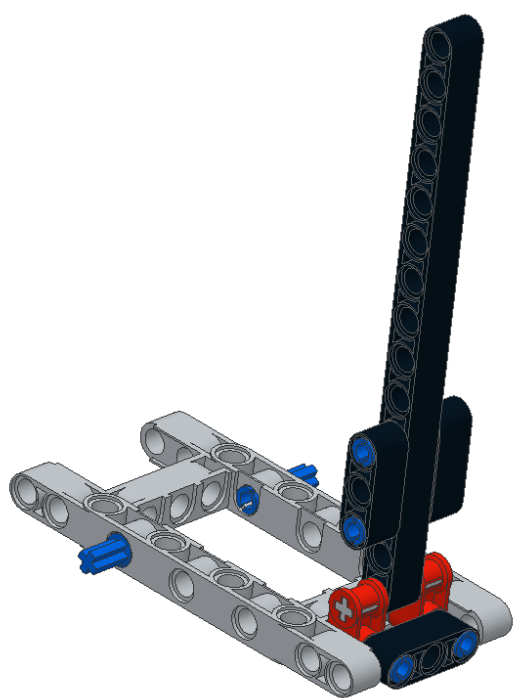
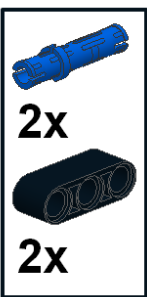

4

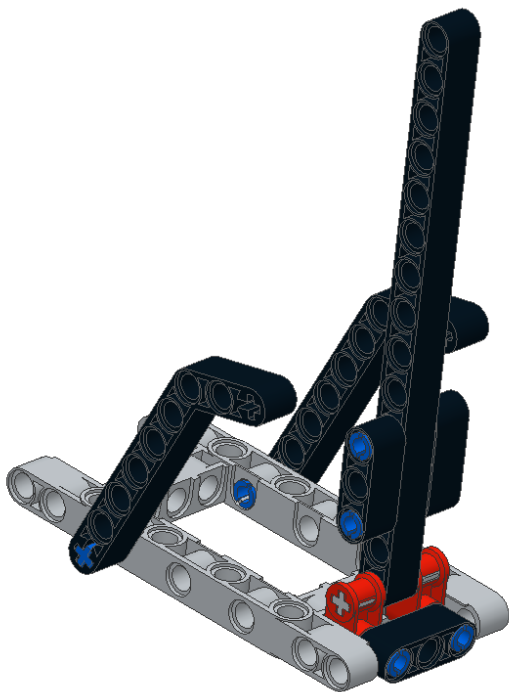
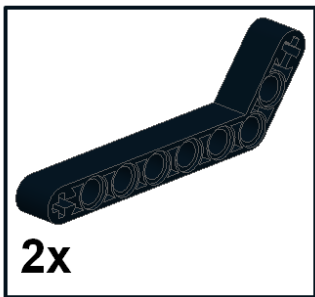

5



1x

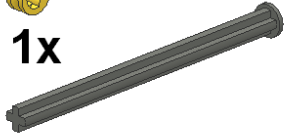

1x

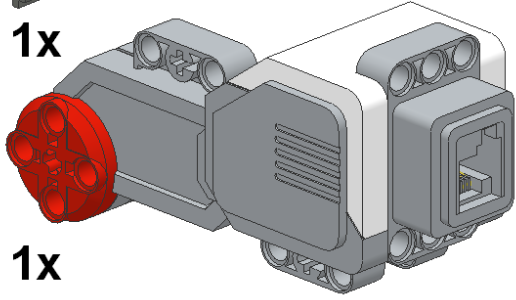

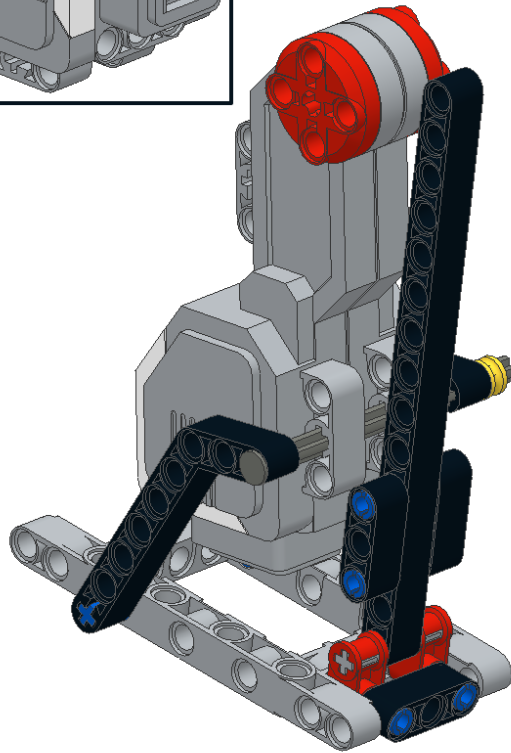

1x

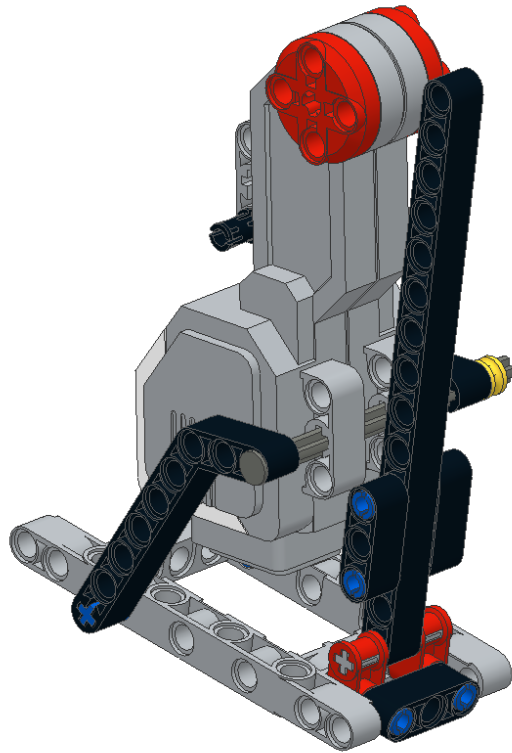

6 
1x

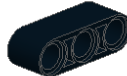

7

- 
1x
- 
1x
- 
1x

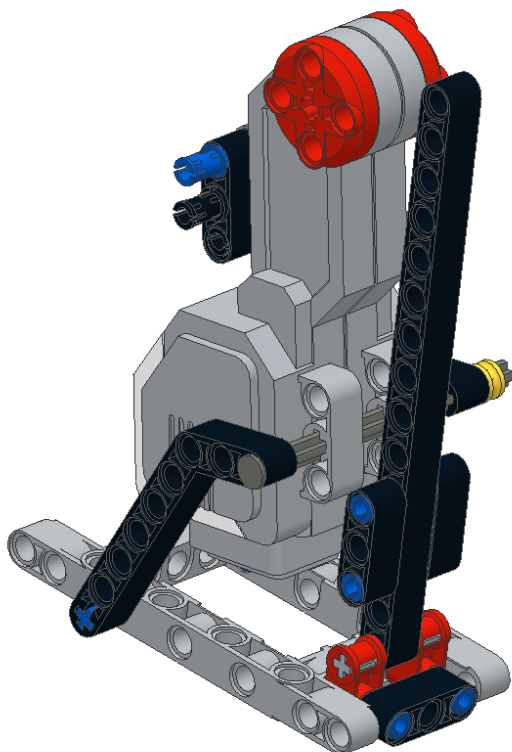

8

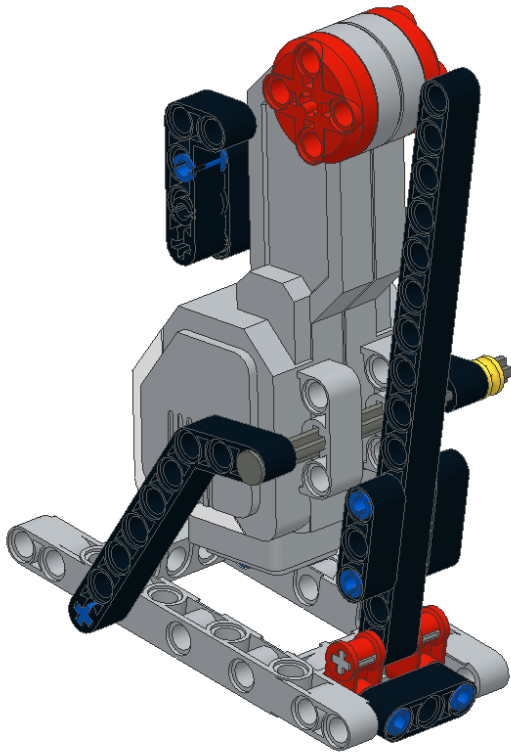
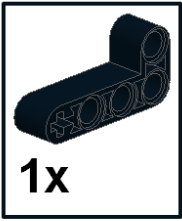

9

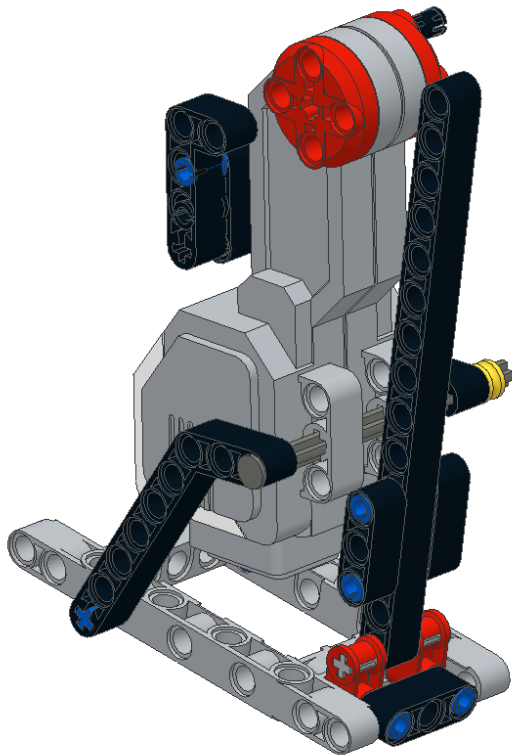

10

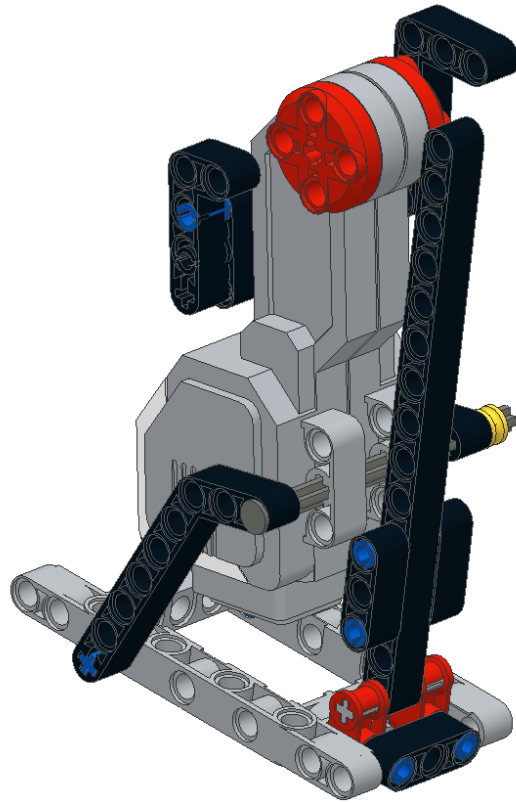
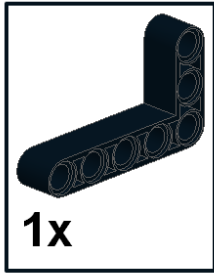

11 
2x

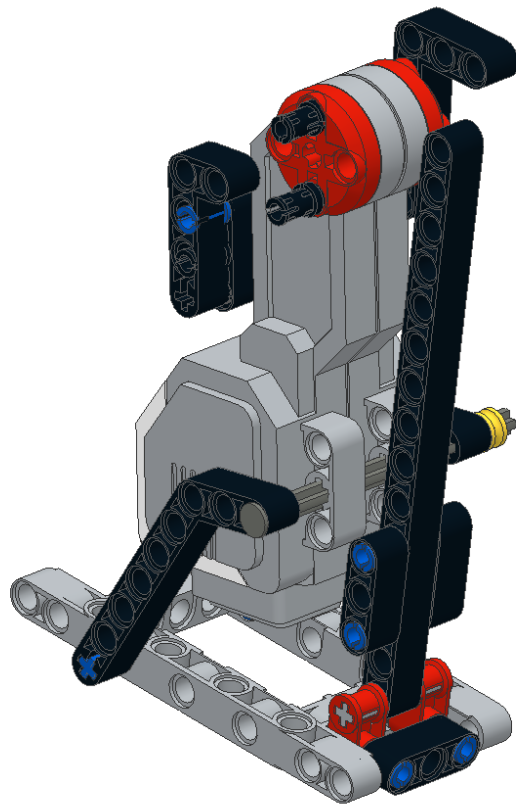

12 
1x

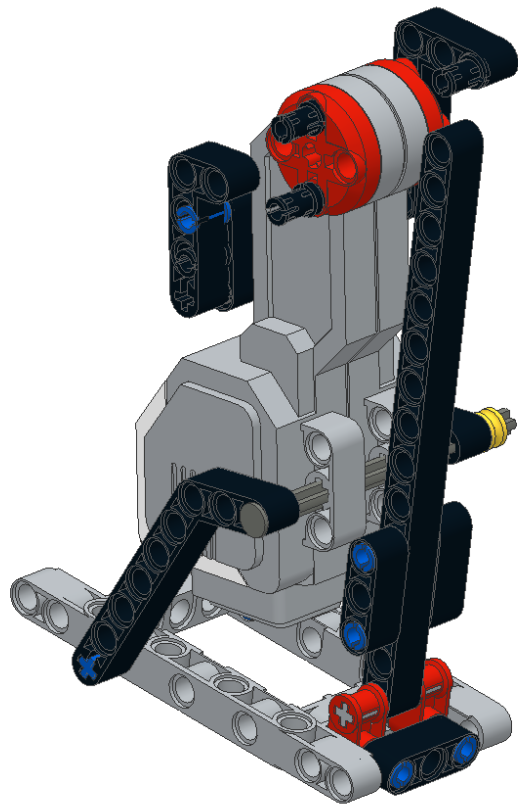

13

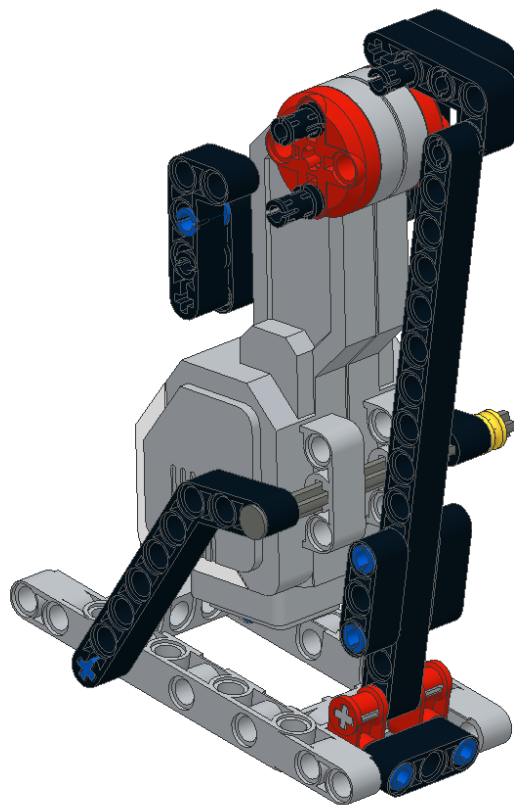
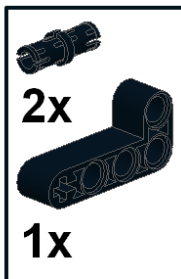

14

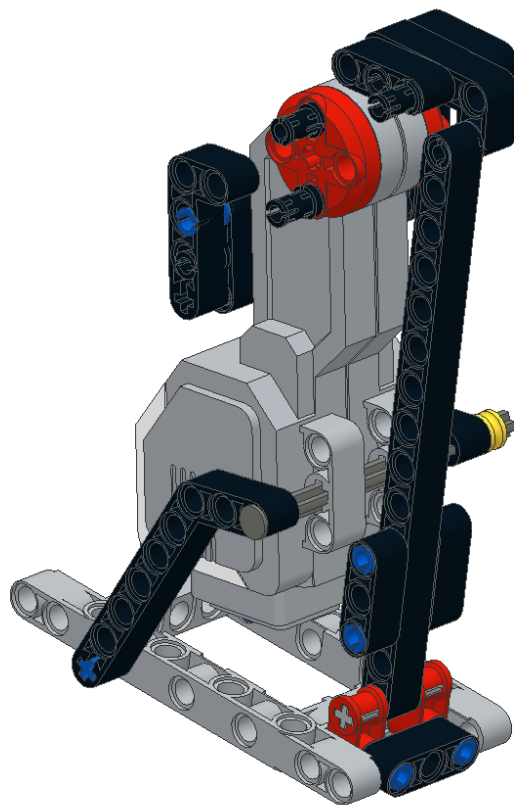
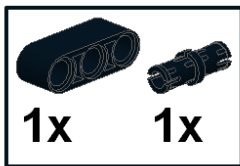

15

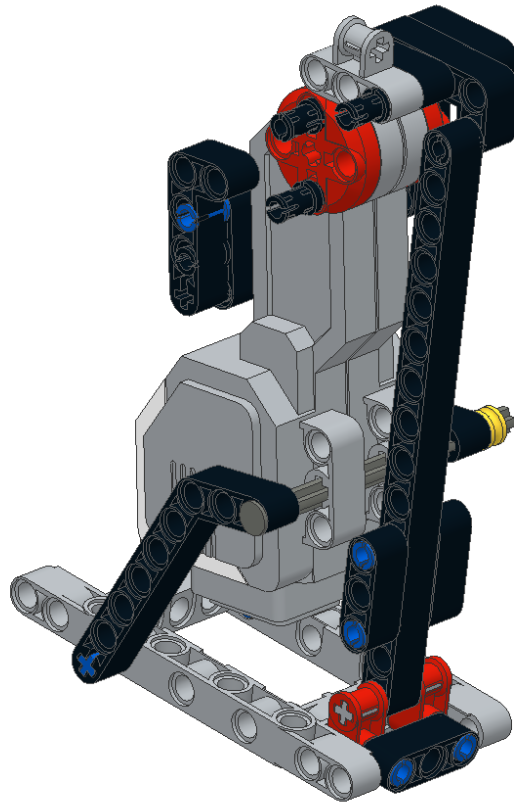
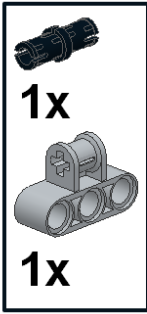

16

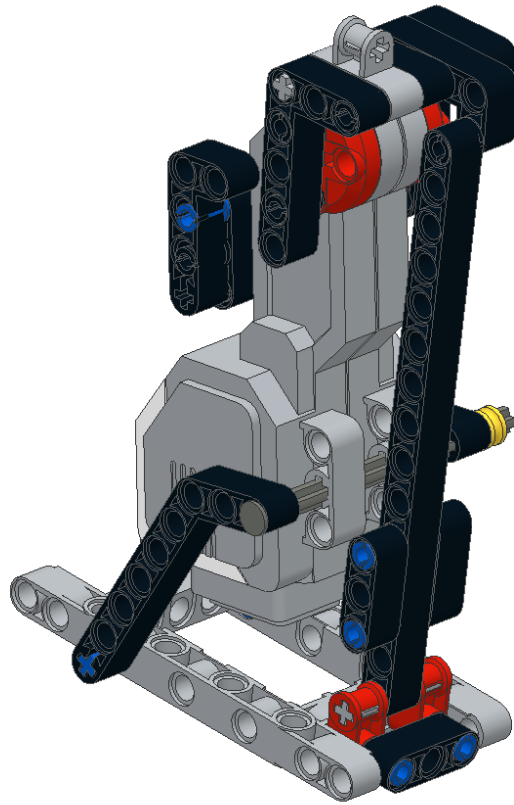
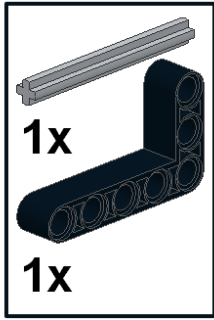

17

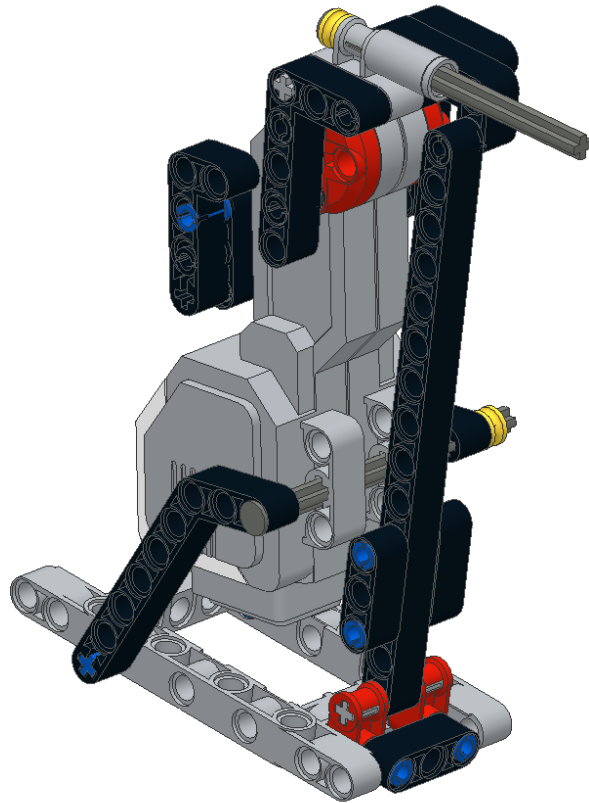
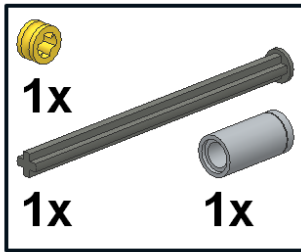

Left Leg



1

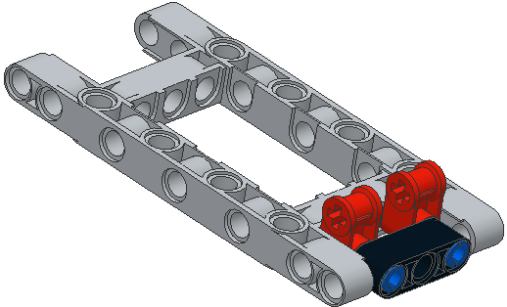
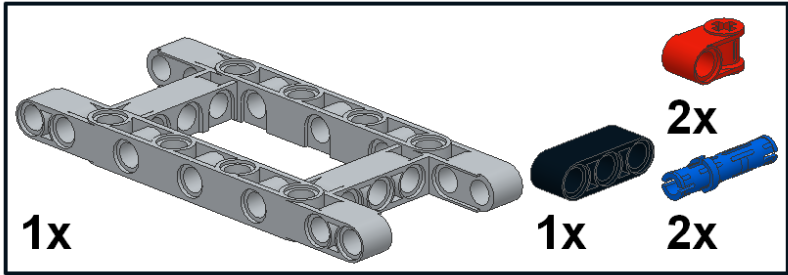

2

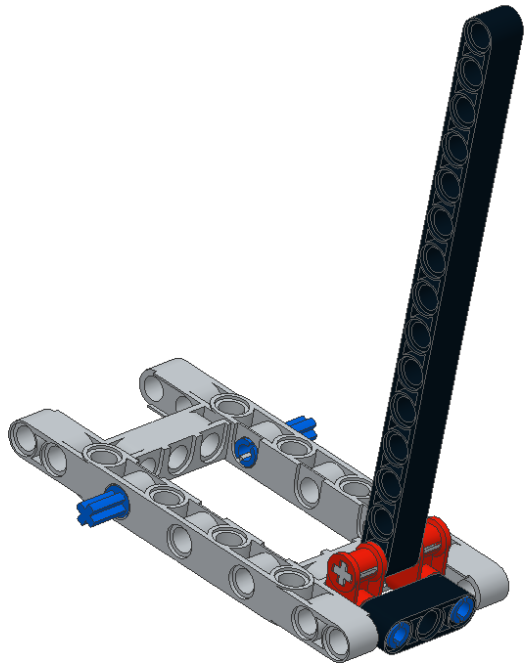
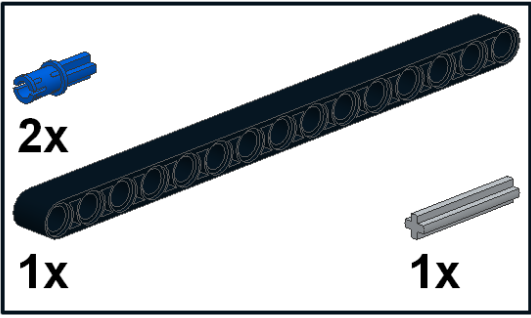

3

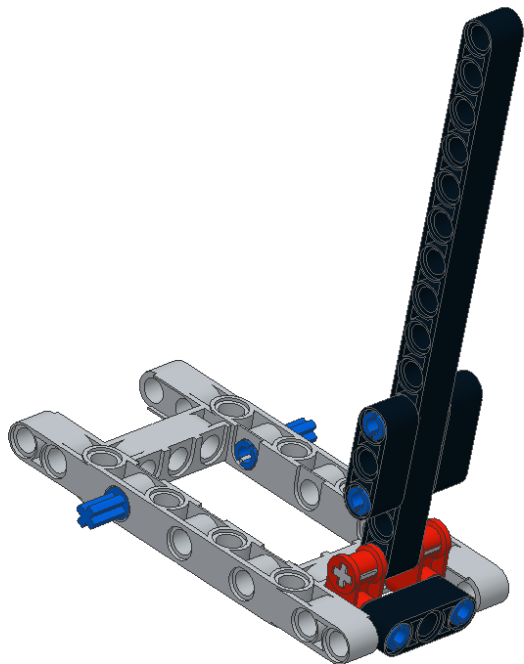
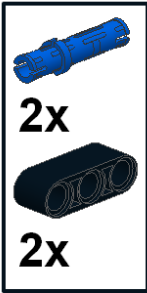

4

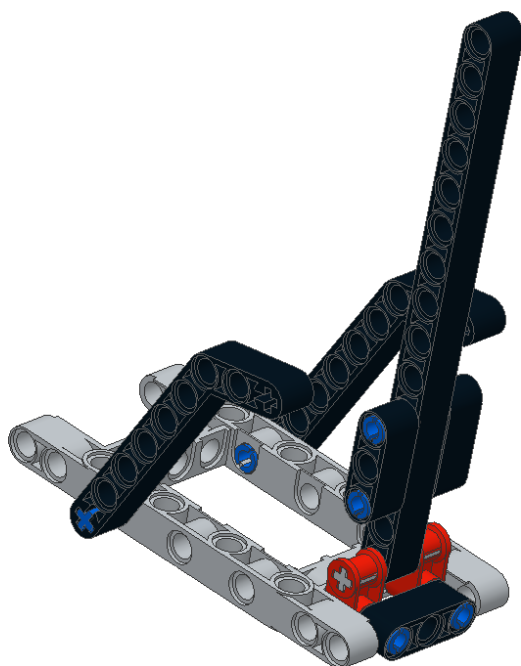

5



1x

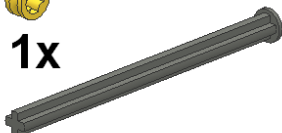

1x

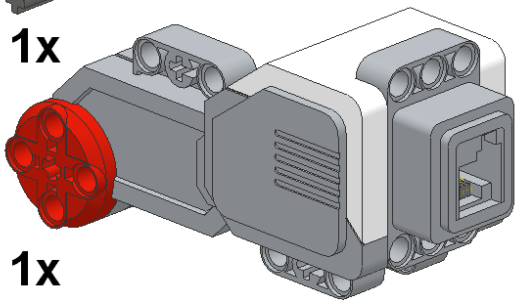

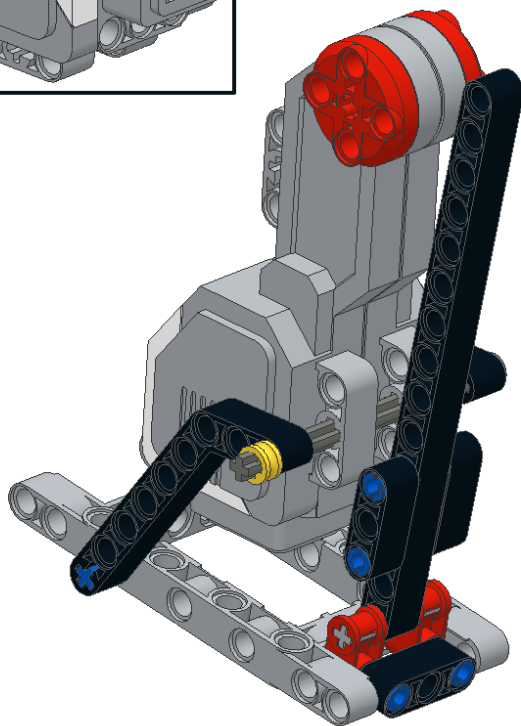

1x

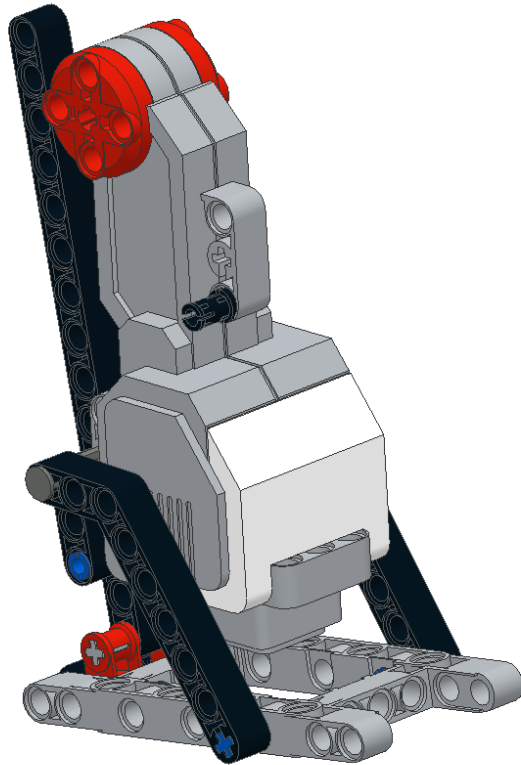

6 
1x

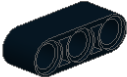

7

- 
1x
- 
1x
- 
1x

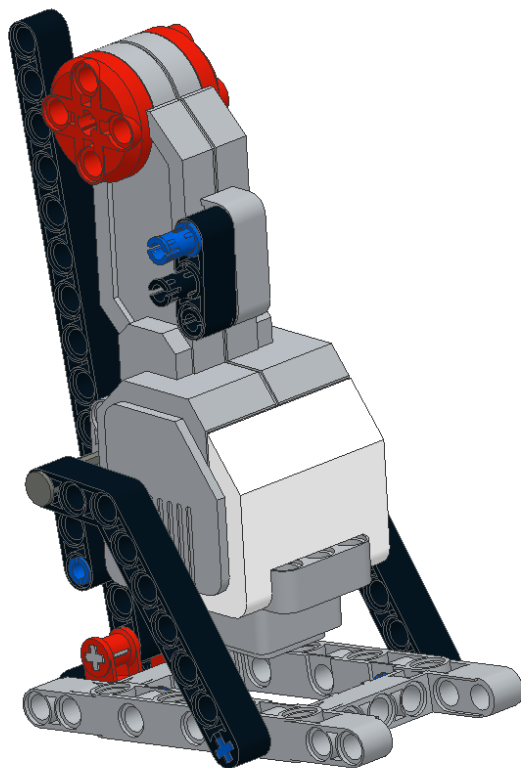

8

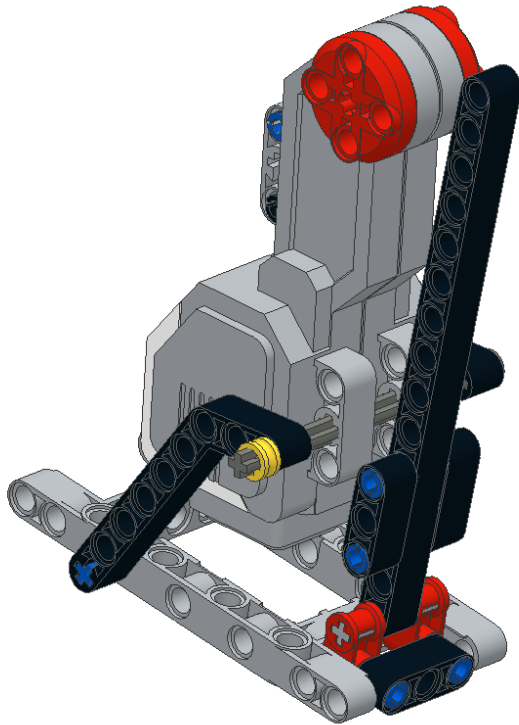
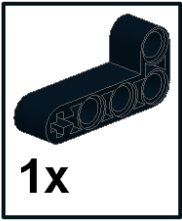

9 
2x

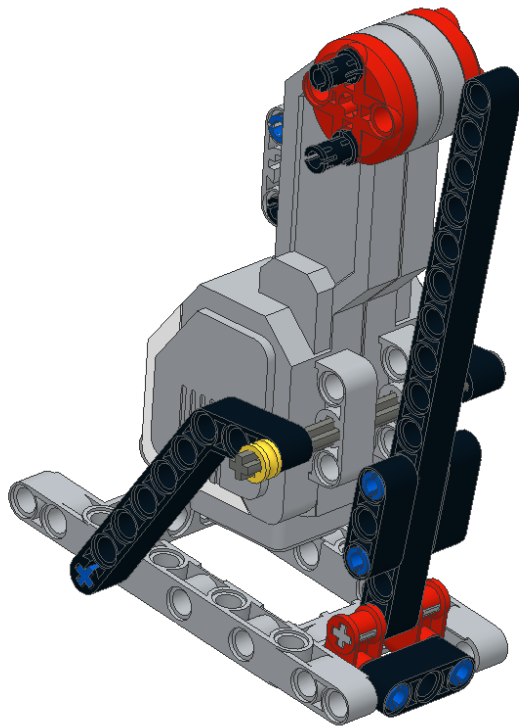

10

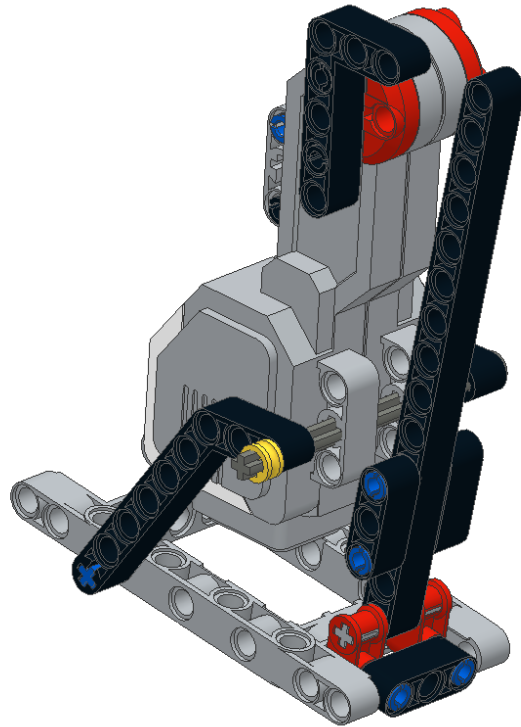
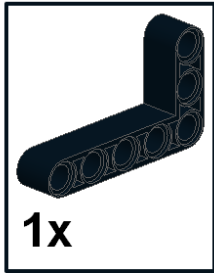

11

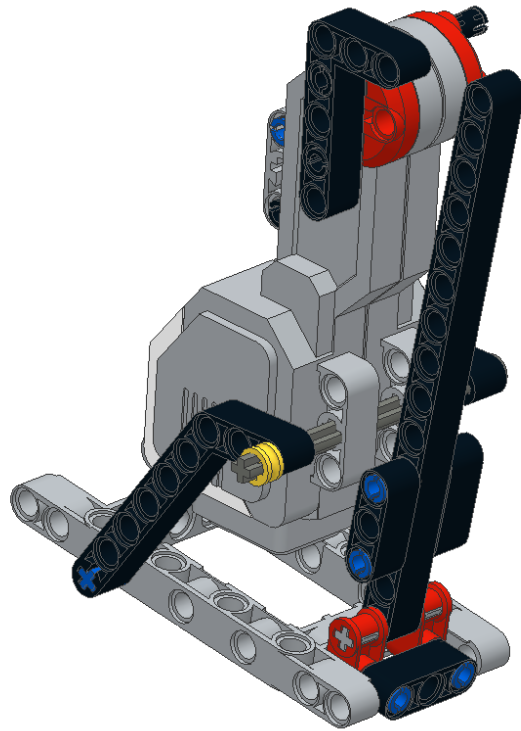

12 
1x

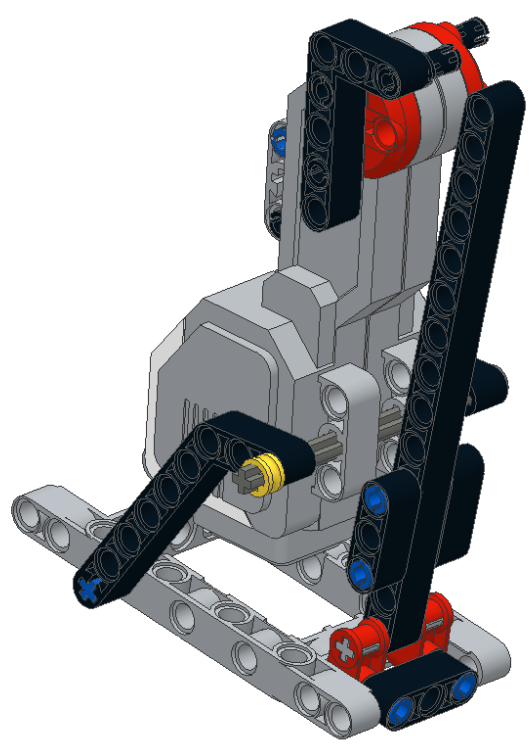

13

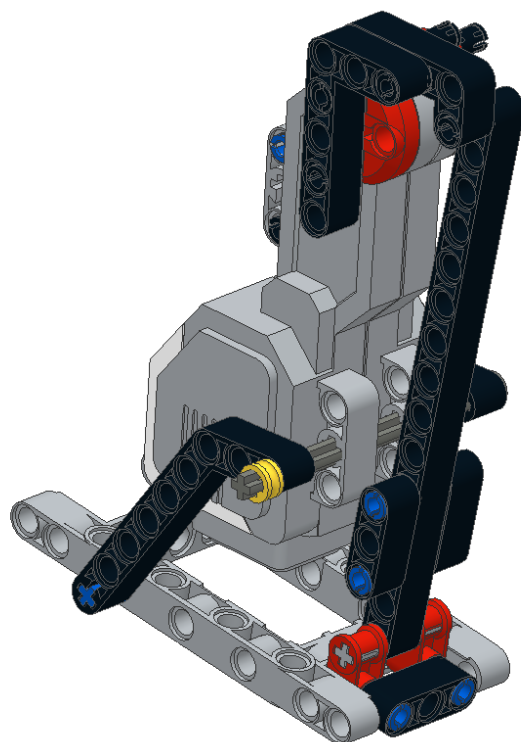
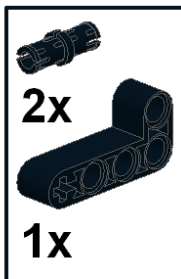

14

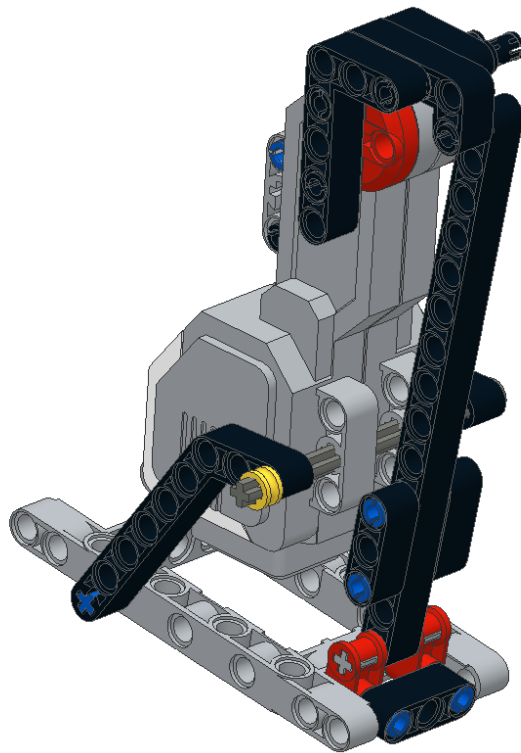
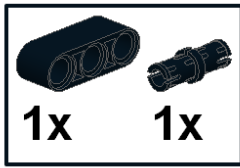

15

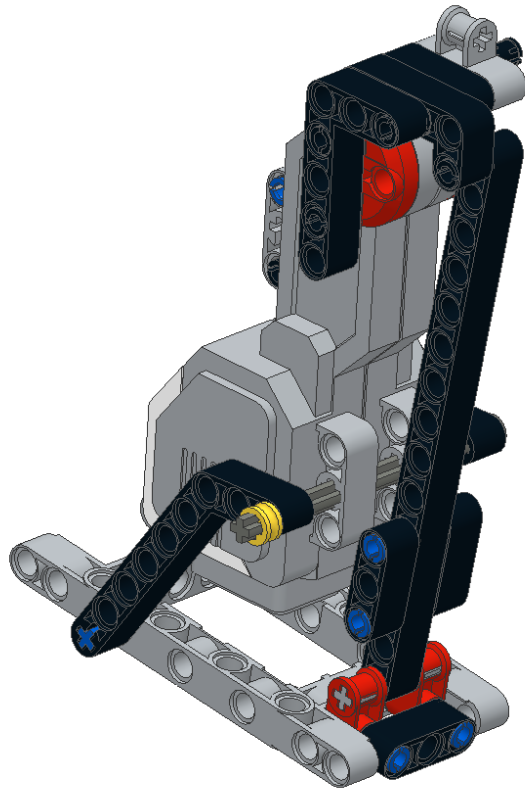
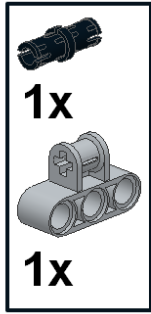

16

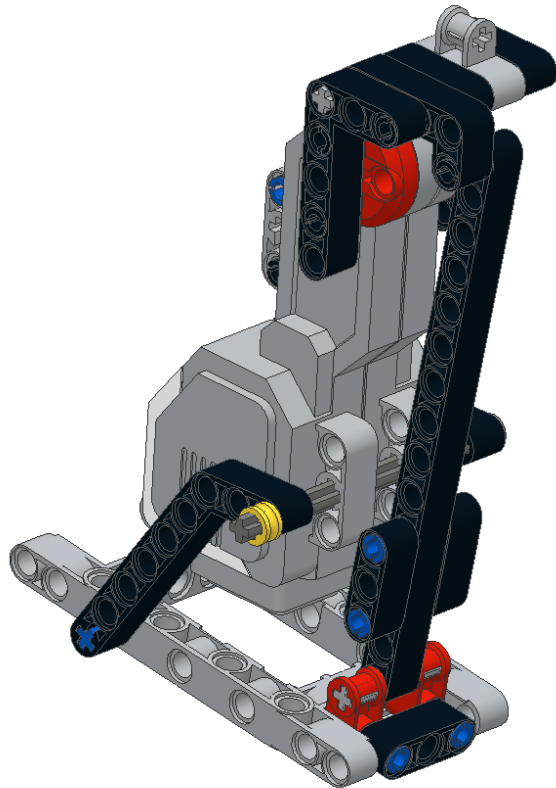
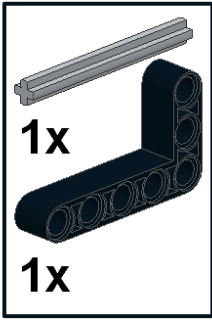

17

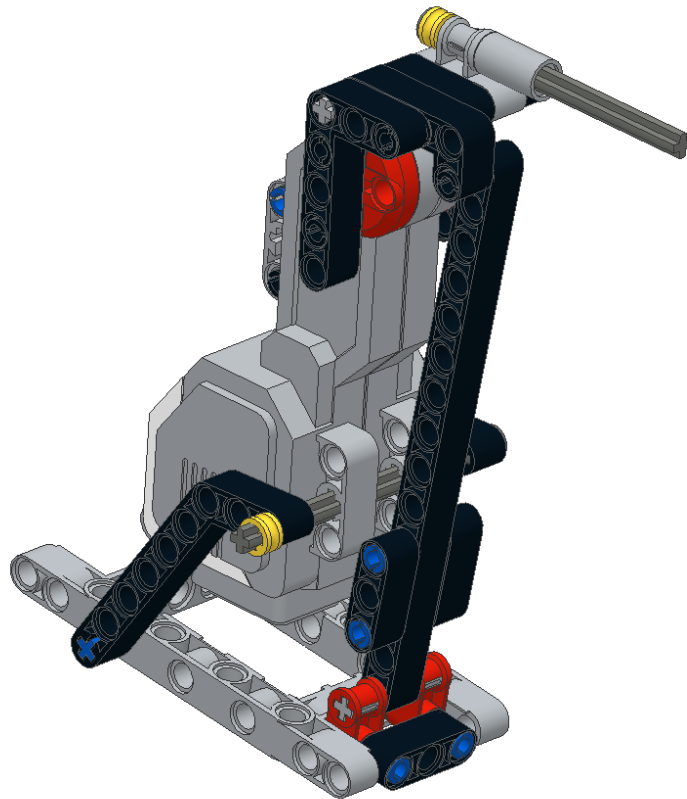
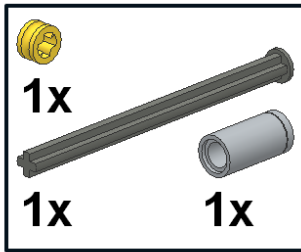

Right Arm



1

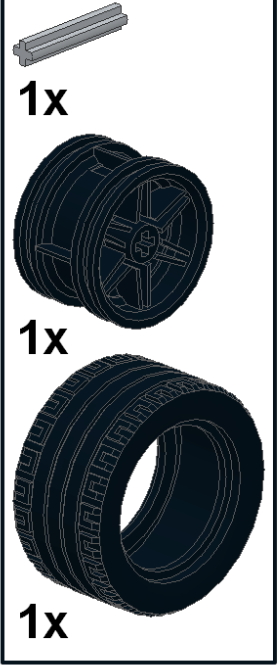

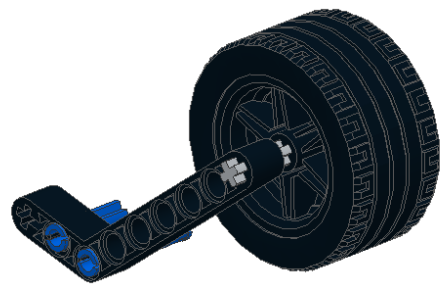
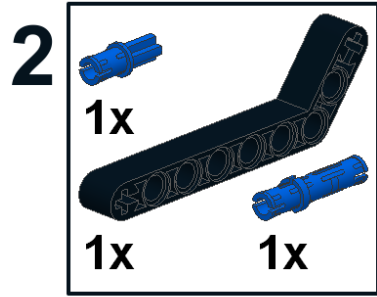

3

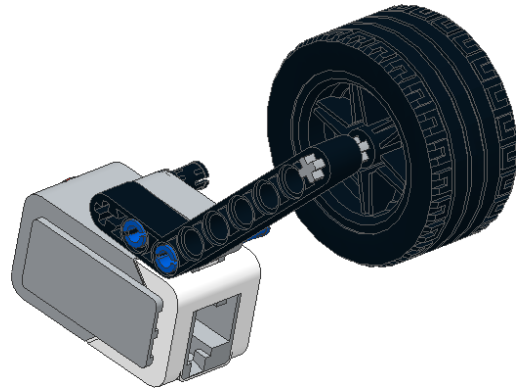
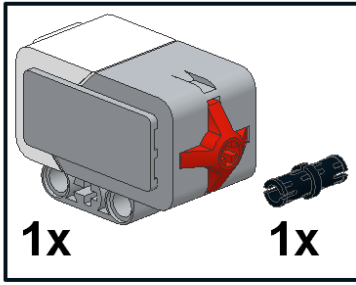

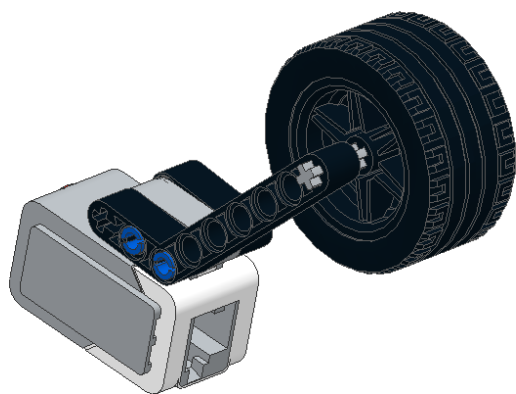
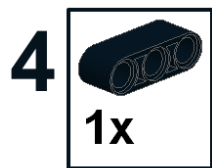

5 
1x

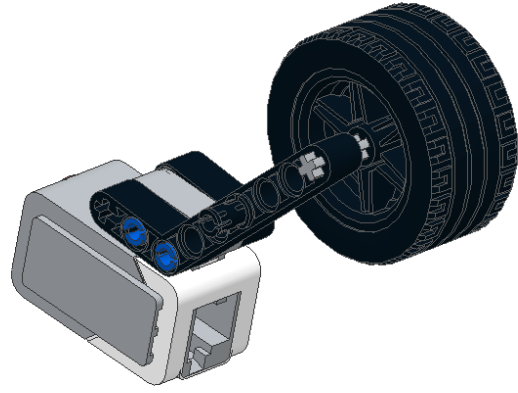

6

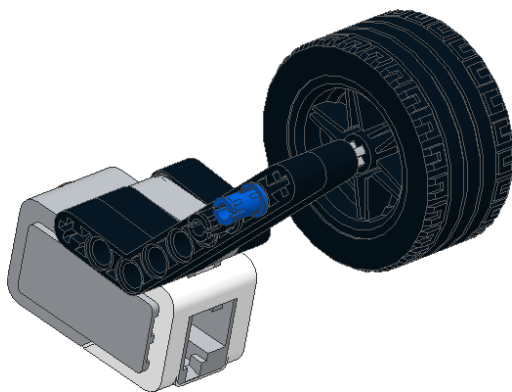
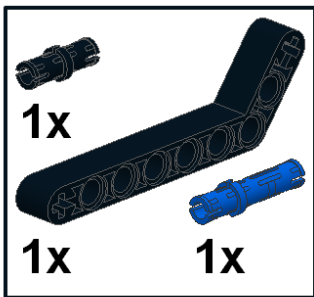

7

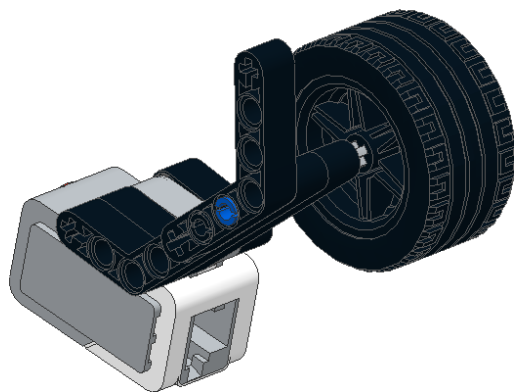
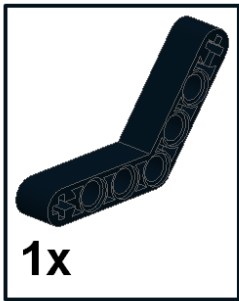

Left Arm



1

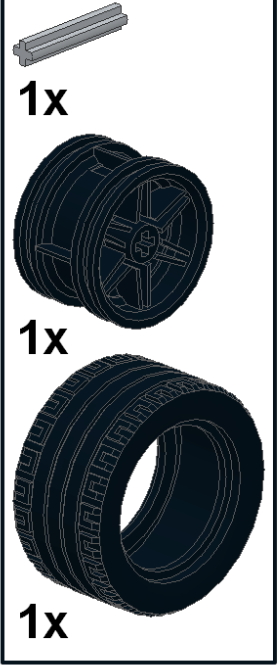

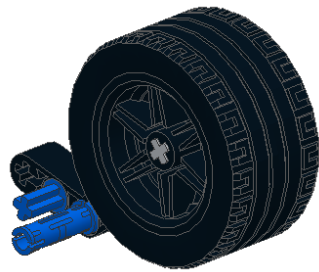
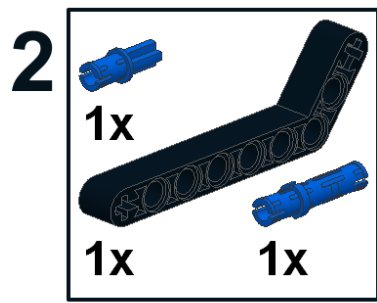

3

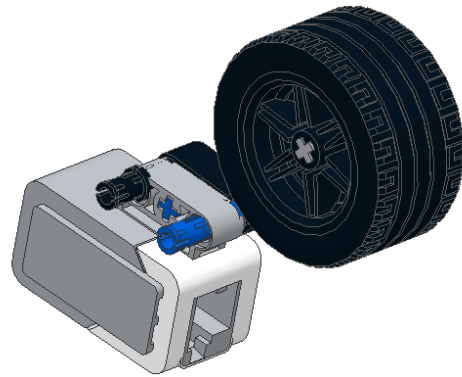
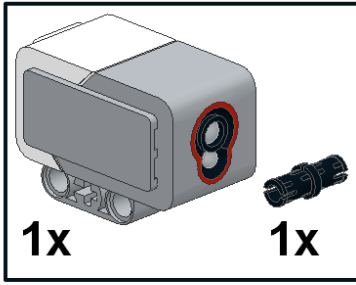

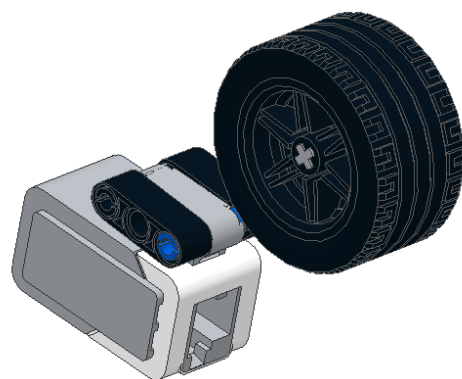
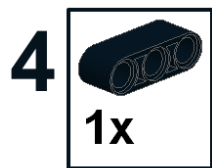

5 
1x

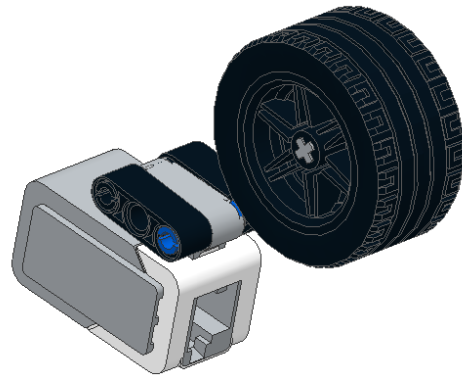

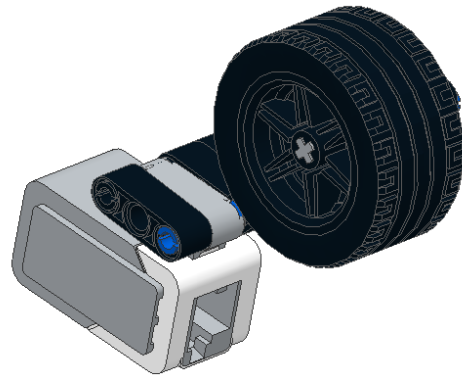
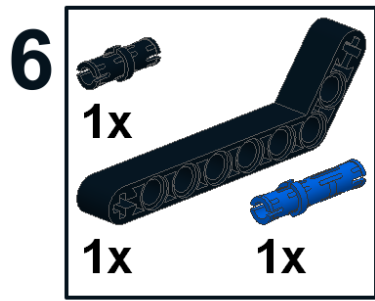

7

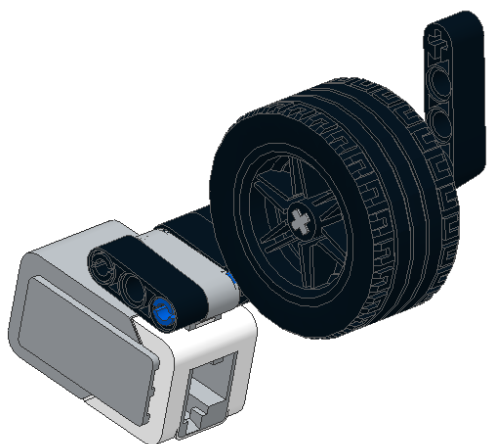
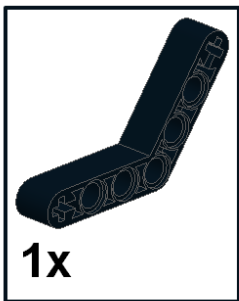

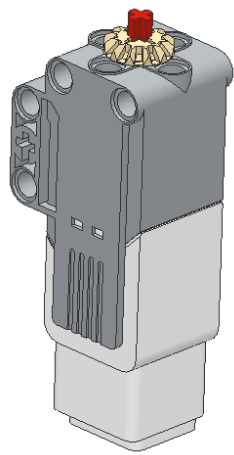
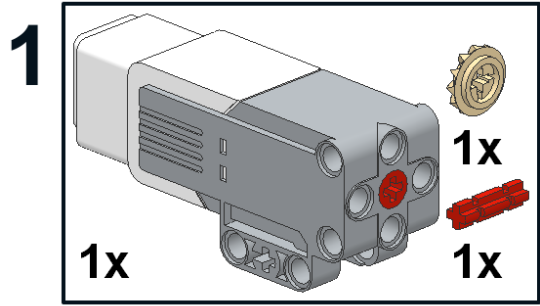

2 
4x

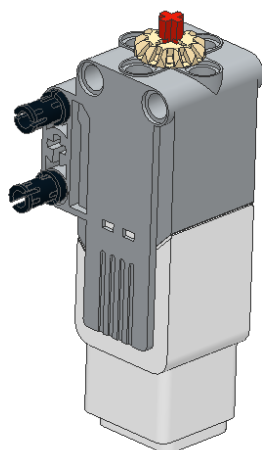

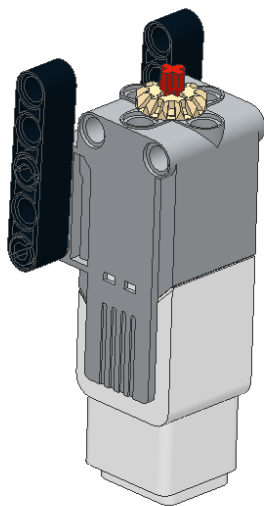
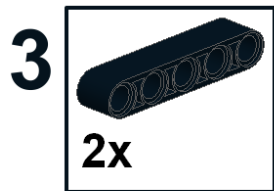

4 
4x

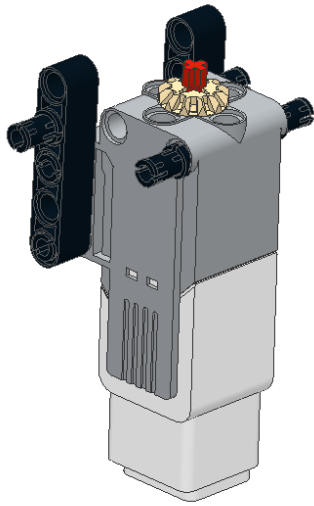

5



2x

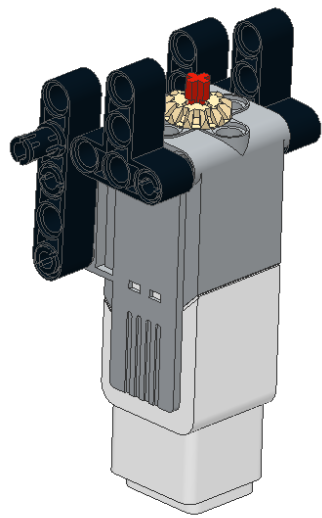

6

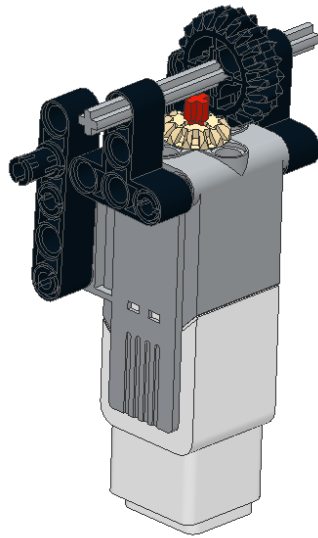
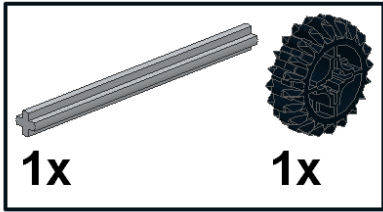

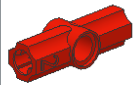
7 
2x

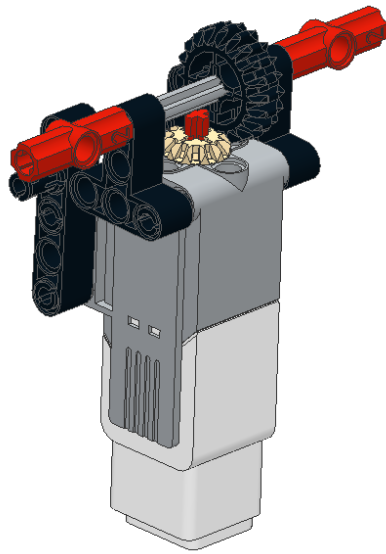

Robot Head

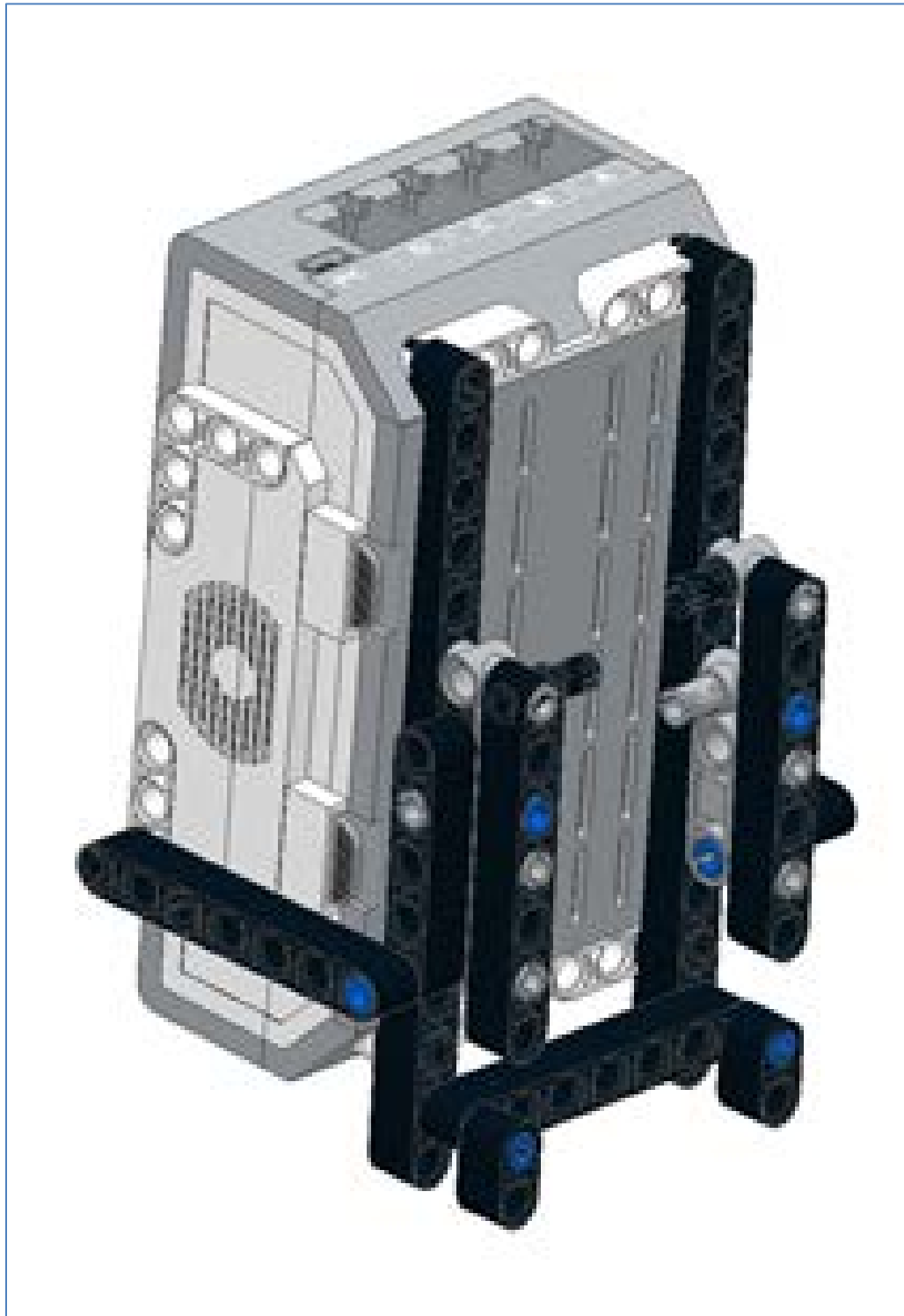

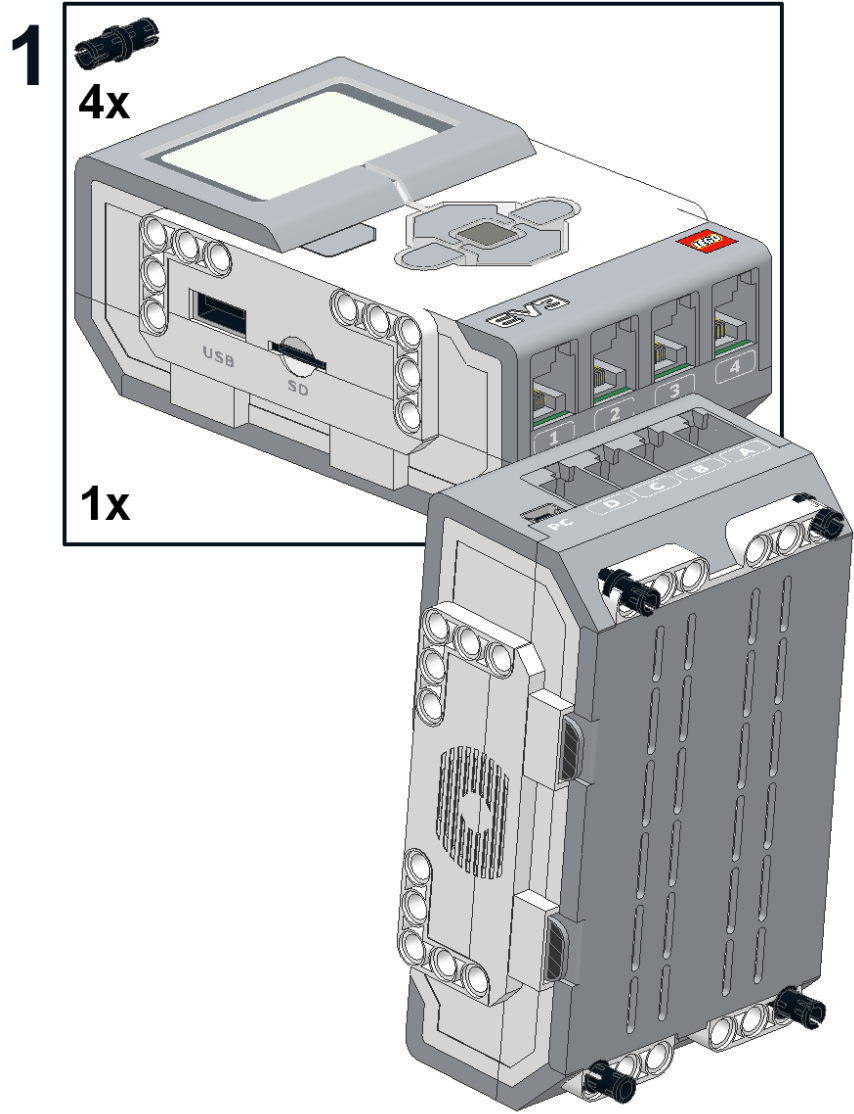

2

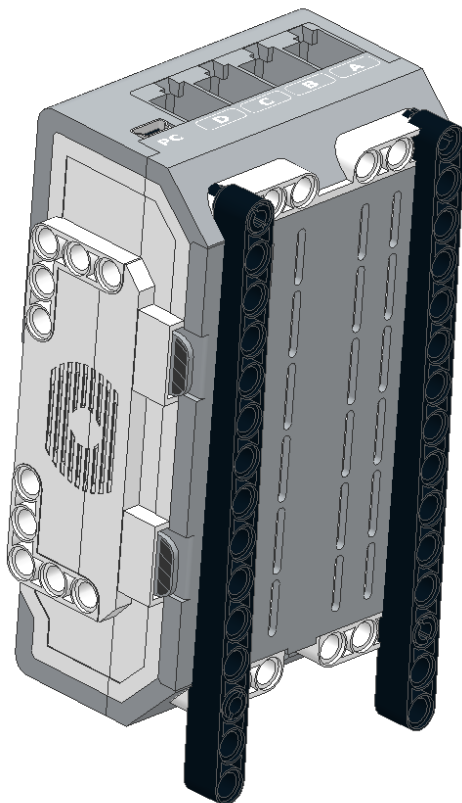
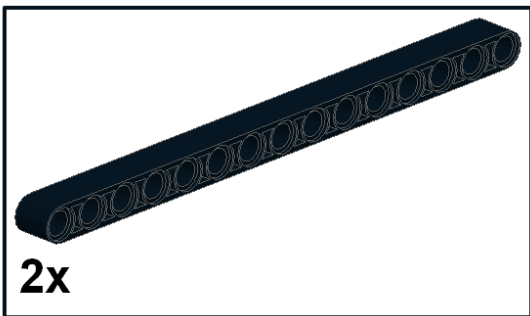

3

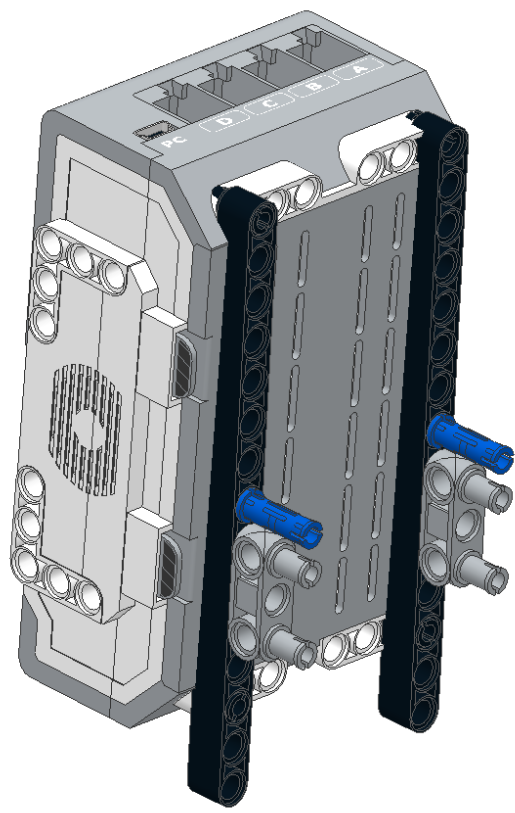
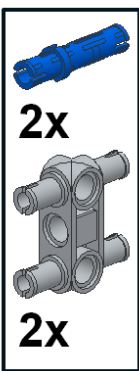

4

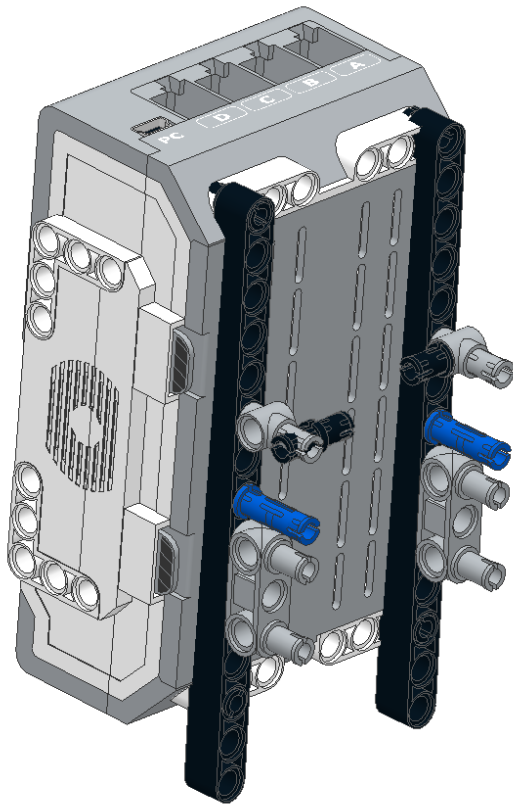
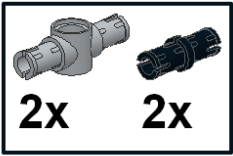

5

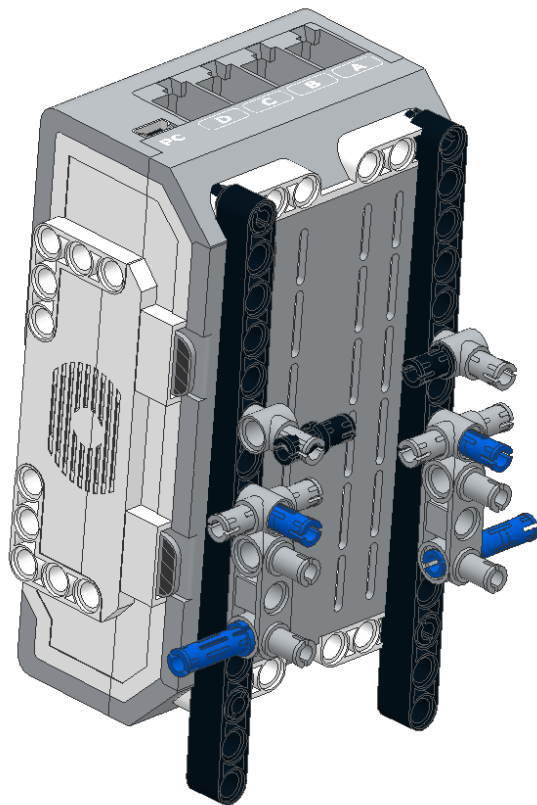

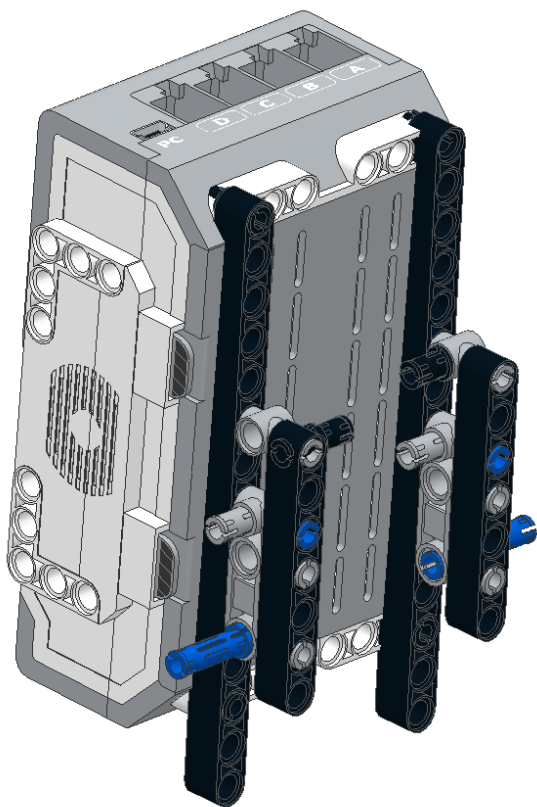
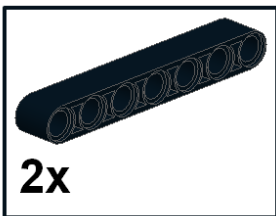

6

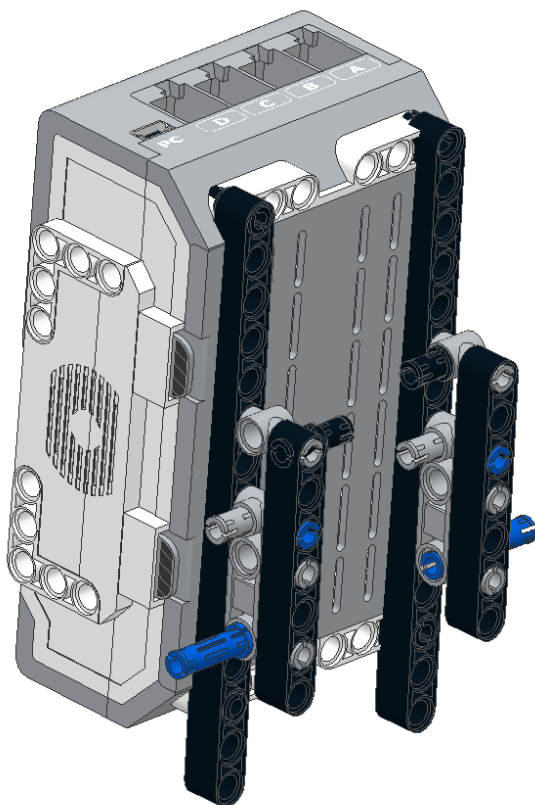
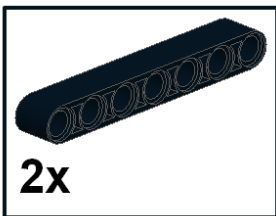

6

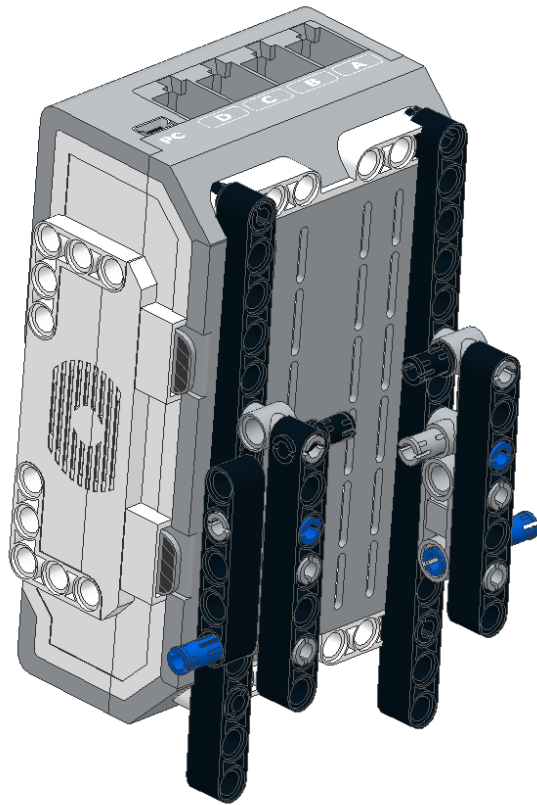
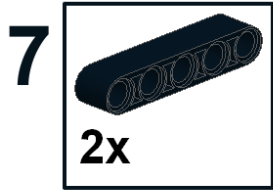



8 
2x

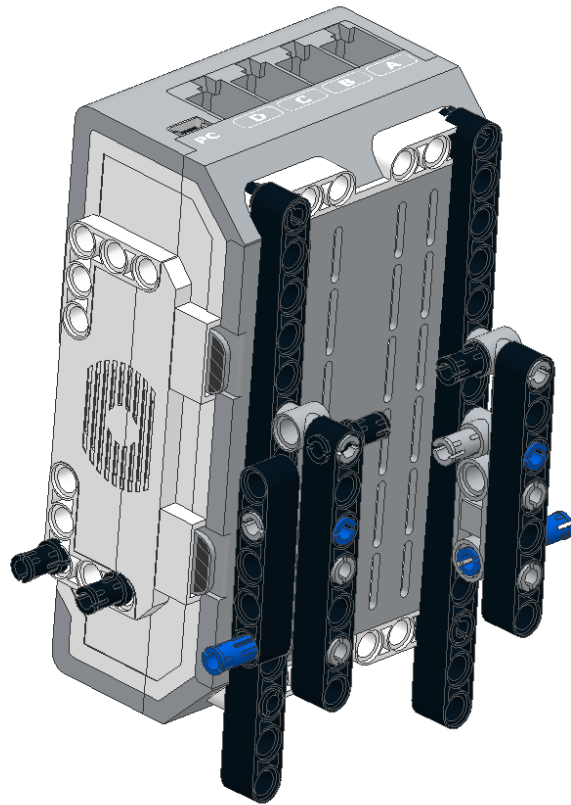

9

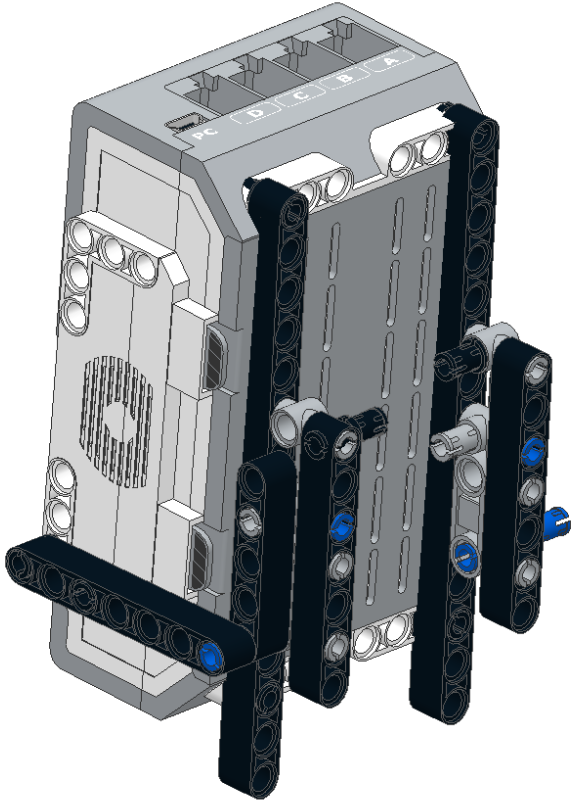
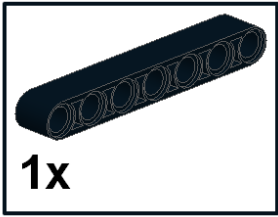

10 
2x

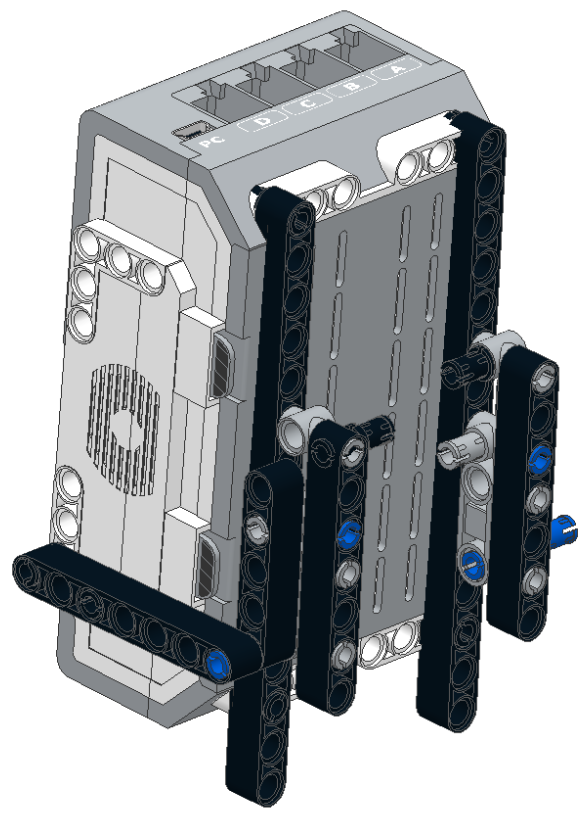

11

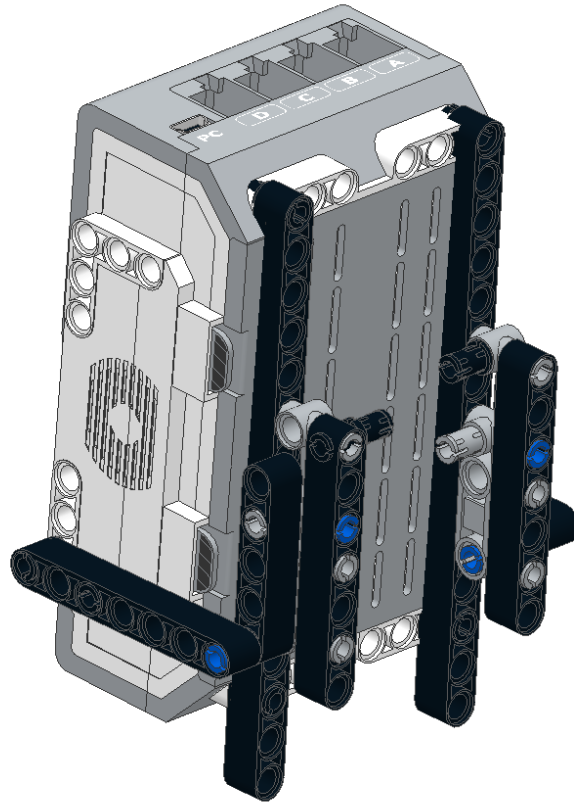
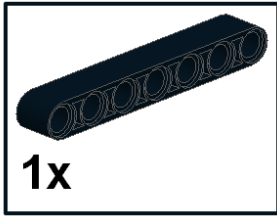

12

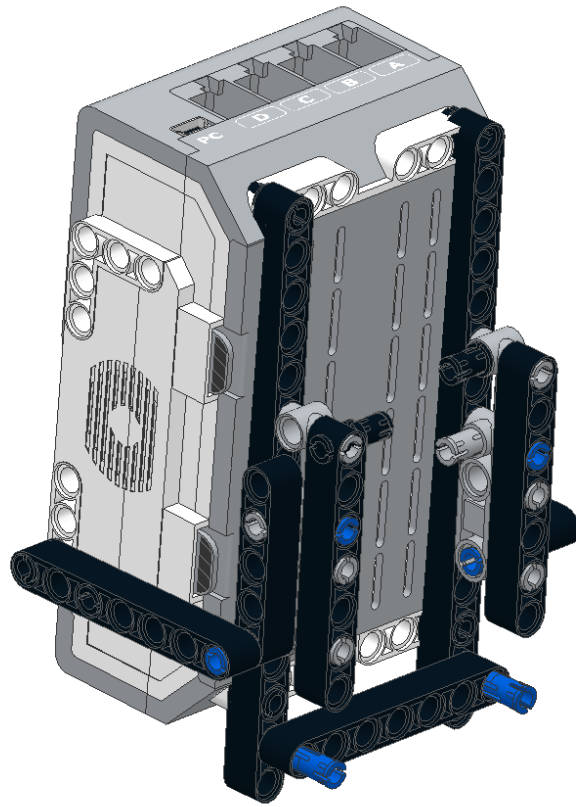
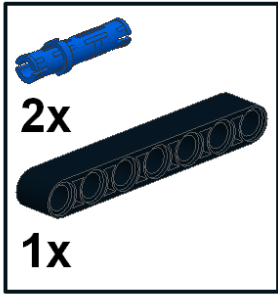

13 
2x

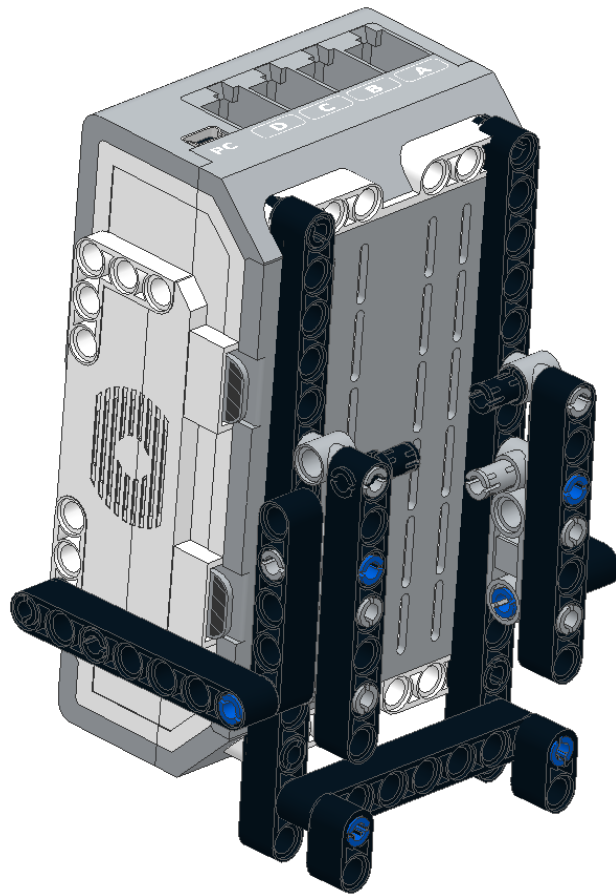

Final Steps

Slide leg pins through holes to connect to the frame.

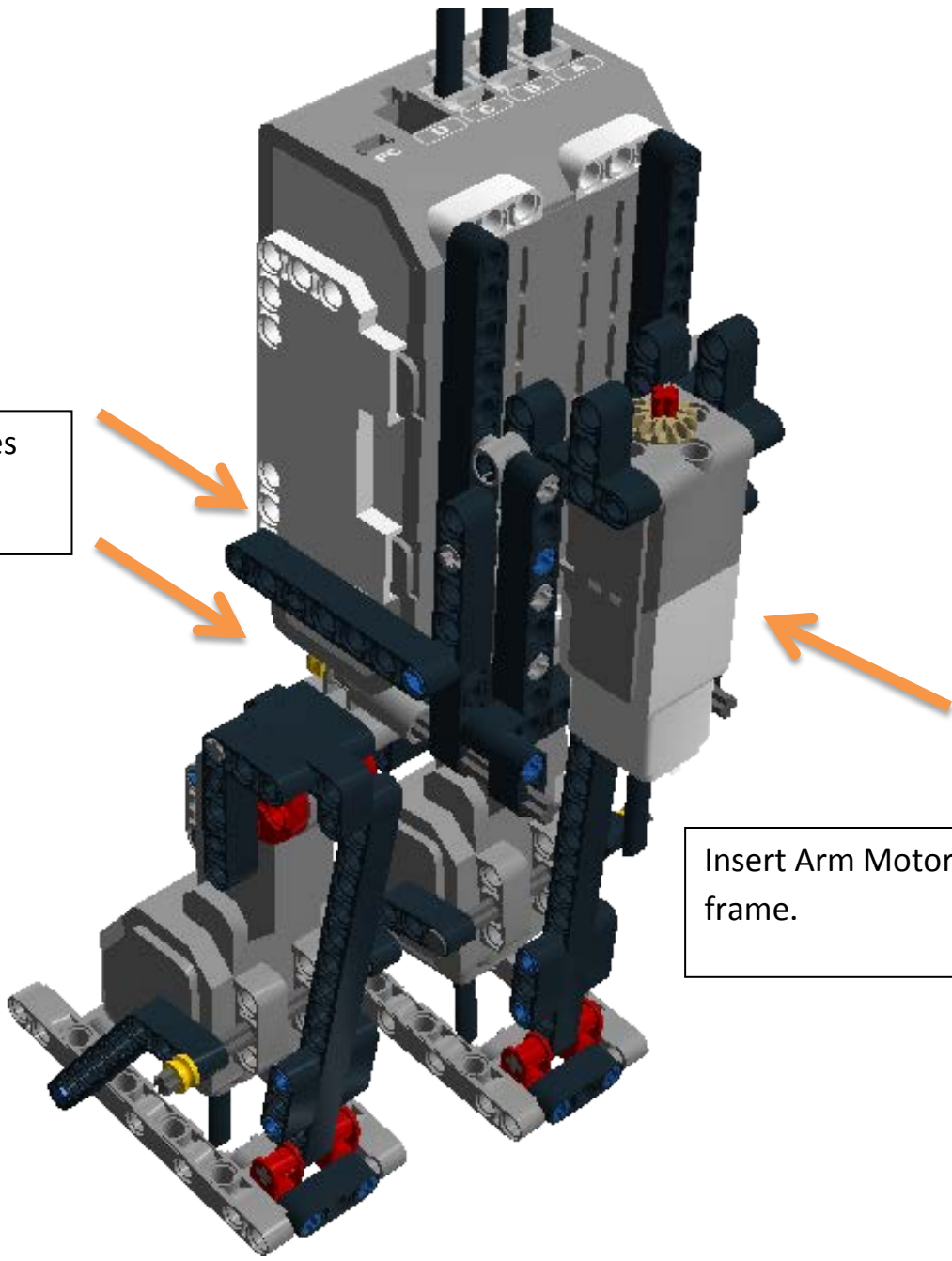

Insert Arm Motor onto frame.

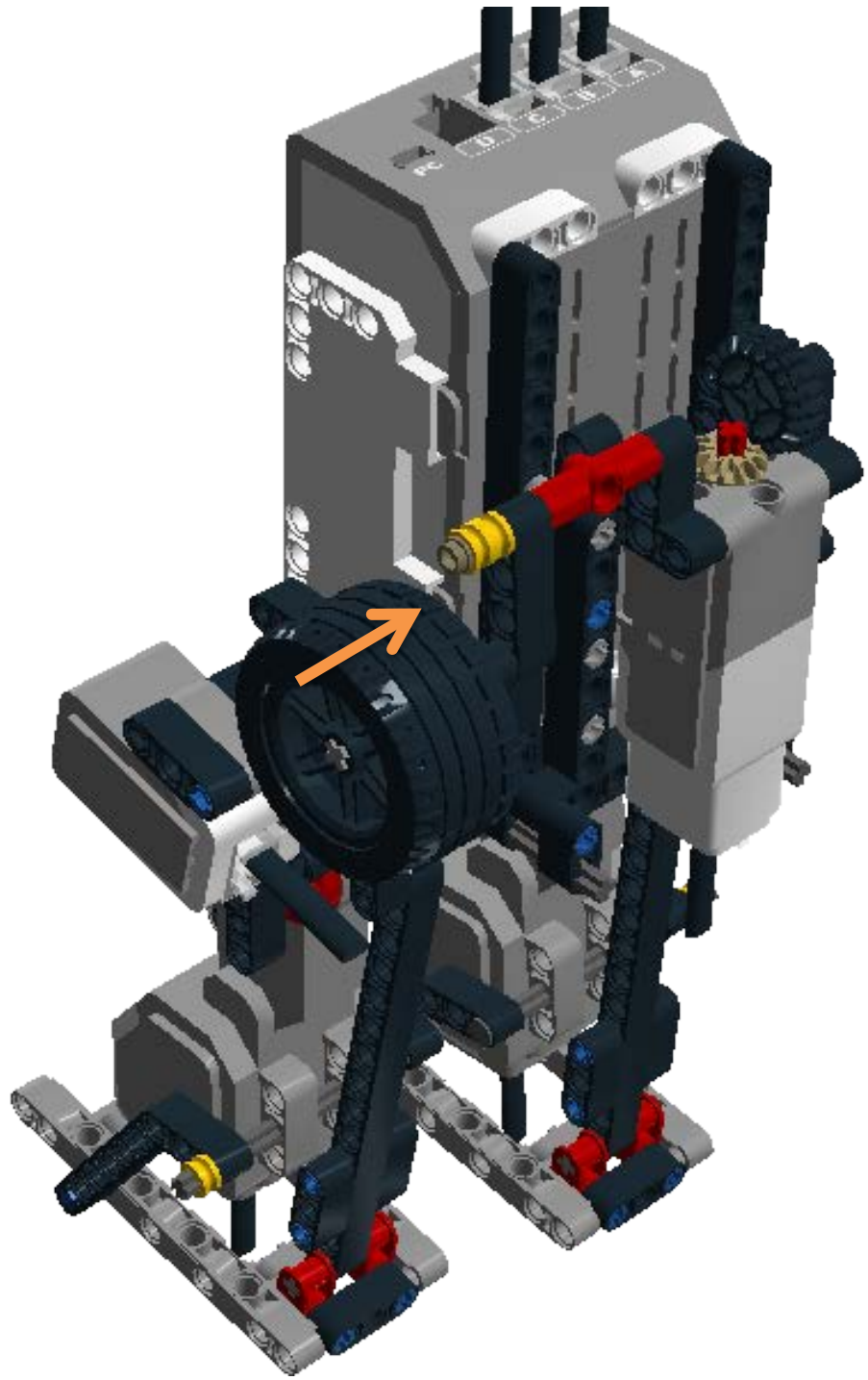

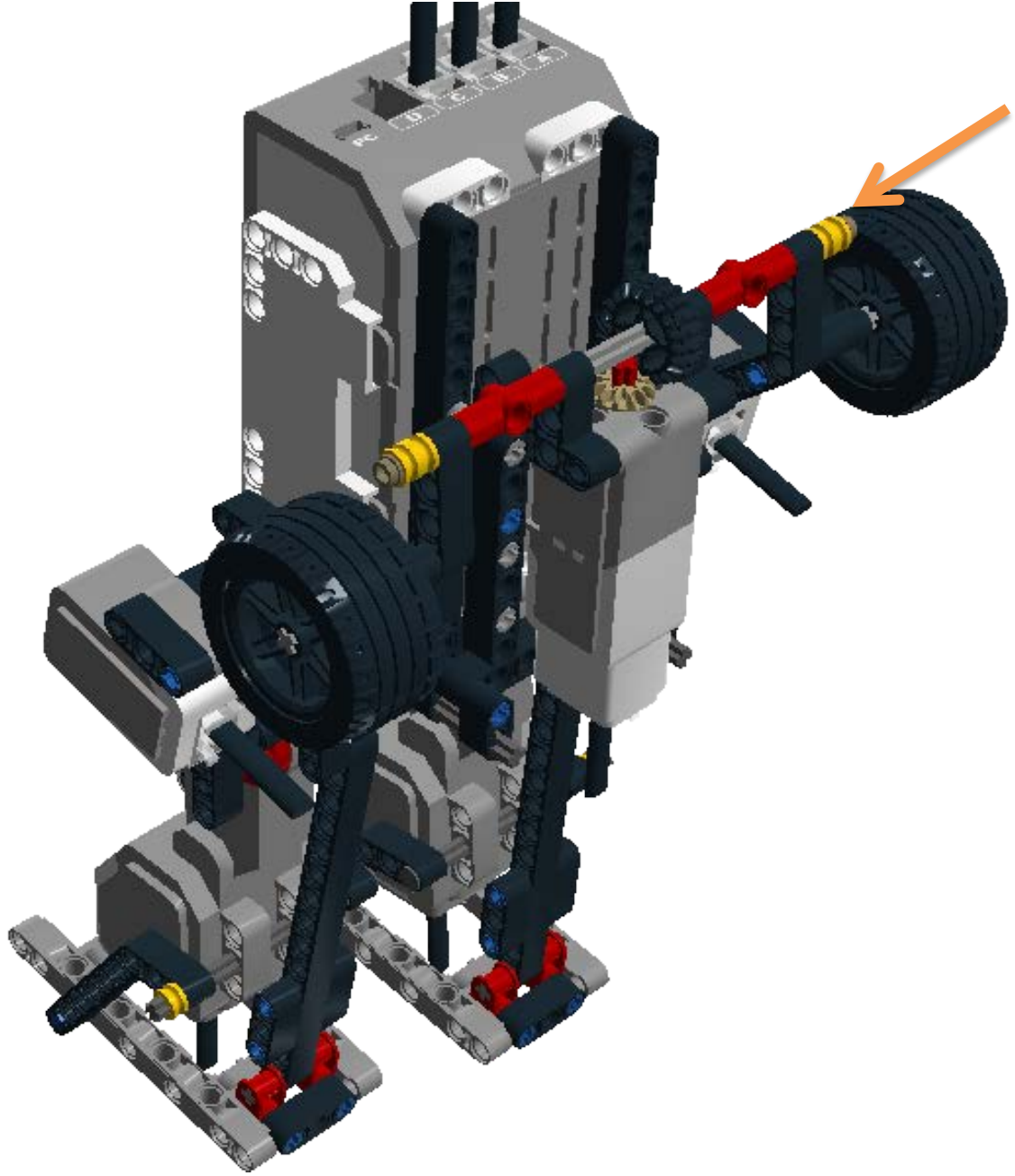

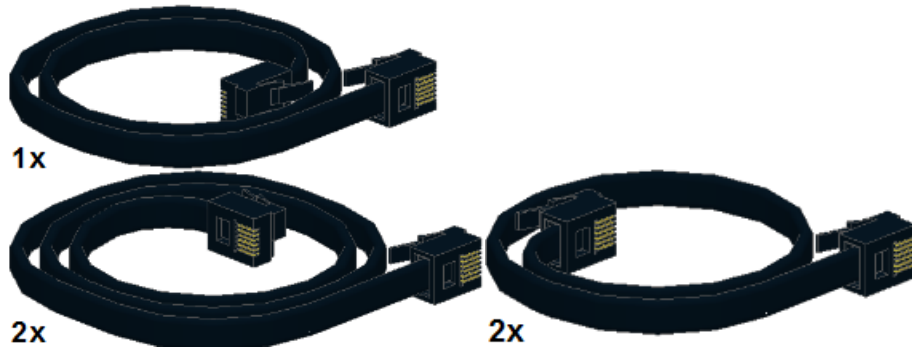

Connect Wires:

25cm Wire from EV3 Color Sensor --> EV3 Brick Port 2

25cm Wire from EV3 Touch Sensor → EV3 Brick Port 1

35cm Wire from Medium Motor → EV3 Brick Port A (Route behind medium motor)

50cm Wire from Left Leg large motor → EV3 Brick Port C

50cm Wire from Right Leg large motor → EV3 Brick Port B

(Route 50cm Wires behind 8cm leg pins and behind medium motor)

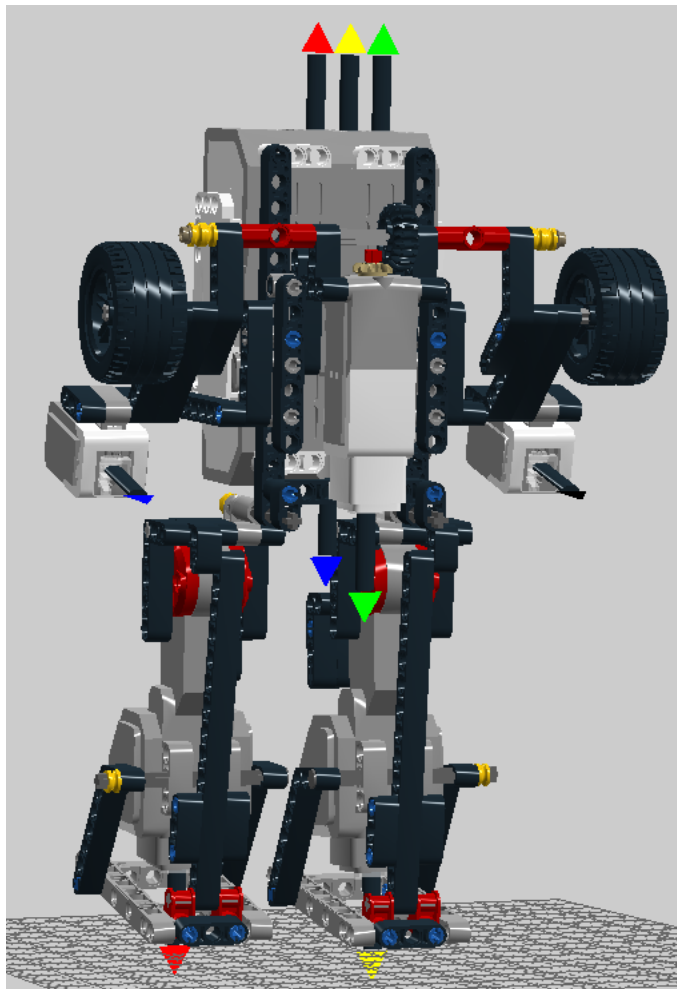

6x



1x

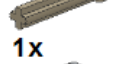

1x



2x



4x



4x



2x



2x



1x

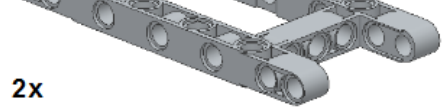

2x



4x

2x



4x

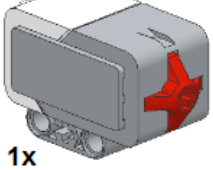

1x

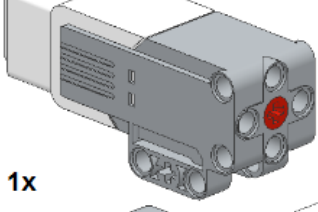

1x

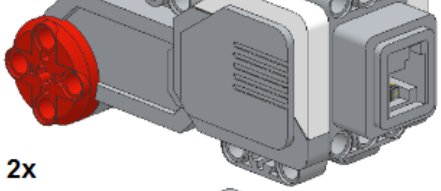

2x

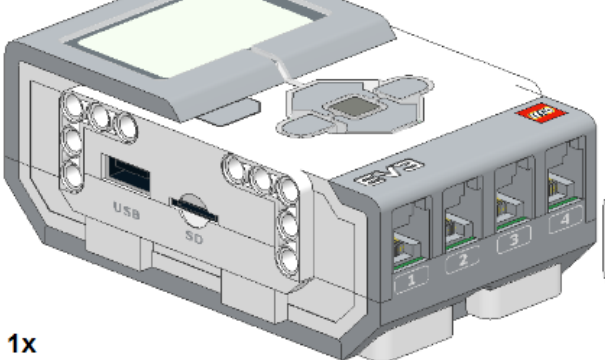

1x

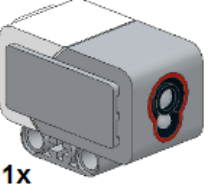

1x



5x



8x

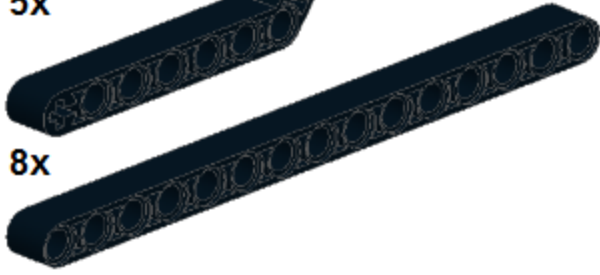

4x



6x



20x



1x



4x



2x

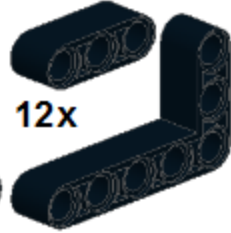

12x



4x



2x



2x



2x



46x



2x



1x



2x



4x



4x